

SUBMITTAL SHEET

JOB NAME _____ ITEM TAG _____

JOB LOCATION _____ PART NUMBER _____

CONTRACTOR _____ DATE _____

ENGINEER APPROVAL _____ DATE _____

BRASS SWING CHECK VALVE

T/S-451

Durable, full-pattern cast brass body.

Large, integral seat and disc sealing surfaces.

Forged brass hinge pin assures smooth, non-binding disc operation.

T-pattern body permits either vertical (upward flow only) or horizontal (assembly cap upright) installations.

1/2-P.S.I. cracking pressure. Less than 1 P.S.I. back-pressure required to facilitate the closure seal.

Working Pressure, Non-Shock (PSI)

Cold Water, Oil, Gas: 200 CWP

Saturated Steam: Not suitable for steam service

- Threaded end connections comply with ANSI/ASME B1.20.1
- Sweat end connections comply with ANSI/ASME B16.18
- Manufactured in an ISO accredited facility

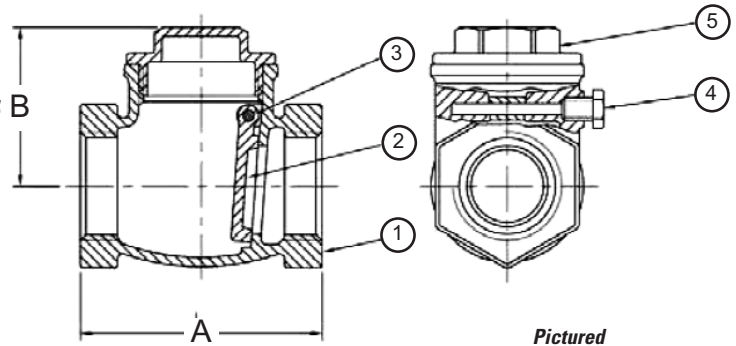

**Pictured
T-451
Cut-away**

MATERIAL SPECIFICATION

PART	MATERIAL	SPECIFICATION
1 Body	Cast brass	ASTM B584 UNS C85700
2 Disc	Forged brass	ASTM B124 UNS C37700
3 Hinge pin	Forged brass	ASTM B16 UNS C36000
4 Pin retaining screw	Forged brass	ASTM B16 UNS C36000
5 Assembly cap	Cast brass	ASTM B584 UNS C85700

DIMENSIONS

Size	A (NPT)	A (CxC)	B (NPT)	B (CxC)
1/4"	2.11	—	1.52	—
3/8"	1.99	—	1.50	—
1/2"	2.07	1.61	1.50	1.50
3/4"	2.34	3.21	1.59	1.59
1"	2.58	3.54	1.69	1.69
1-1/4"	3.15	4.06	1.85	1.85
1-1/2"	3.48	4.49	2.17	2.17
2"	4.19	5.37	2.72	2.72
2-1/2"	5.16	6.88	2.95	2.95
3"	5.79	7.63	3.82	3.82
4"	6.85	—	3.94	—